

PRODUCT DATA SHEET

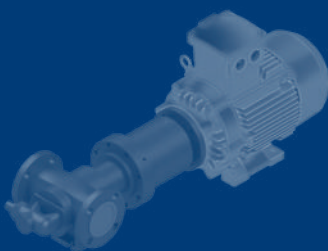
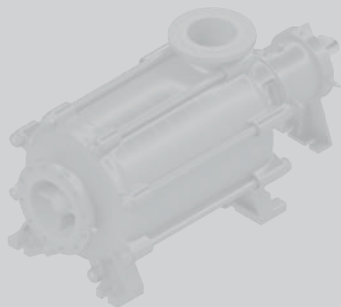

YOUR BENEFIT:

- Increased lifetime
- Optimal energy efficiency
- No personnel & installation efforts needed

THERMAL OIL PUMP **NMX**

THERMAL OIL PUMP NMX

Description / Application

The NMX series are heat transfer pumps of the latest generation for modern thermal oils of all types. The magnetic drive centrifugal pump reliably exceeds even the highest operating limits of today's heat transfer fluids. Unlike comparable products on the market, the NMX is self-degassing and does not require any external cooling. This offers a pure „plug and play“ solution that reliably protects against faulty operation. The hermetically sealed containment shell is located in a separate housing and additionally sealed to the atmosphere with a graphite safety packing. In the unlikely event of a containment shell rupture, the escaping pumped medium is thus reduced to a minimum, protecting people and the environment. Another unique selling point is the integrated fan flow deflector (ffd), which prevents unwanted temperature buildup on the antifriction bearing.

Applications

- Oil & Gas
- Chemistry & Petrochemistry
- Offshore
- Industrial heating systems & Heat carriers
- Renewable energy & Environmental technology

Info NMX



Video NMX



THERMAL OIL PUMP NMX

Technical Data

Design

Pump type	Volute casing pump
Stages	Single-stage
Sealing	Magnetic coupling
Set-up	Horizontal
Self-priming	No
Bearings	Sleeve bearing / SiC
Lubrication	Oil

Material

Spheroidal graphite iron (EN-GJS),
Cast steel (GP 240 GH), Austenitic cast steel (1.4408/
1.4571)

Technical Data

Q max*	1400 m ³ /h [6160 gpm]
H max*	250 m [820 ft]
Operating pressure**	24 bar [348 psi/2.4 MPa]
Temperature**	450°C [840°F]
max. speed	3500 rpm

* depending on size and speed

** higher temperatures and pressures on request

Norm

ISO 2858 / ISO 15783

Explosion protection: Category 2 / Zone 1

THERMAL OIL PUMP **NMX**

Sectional View

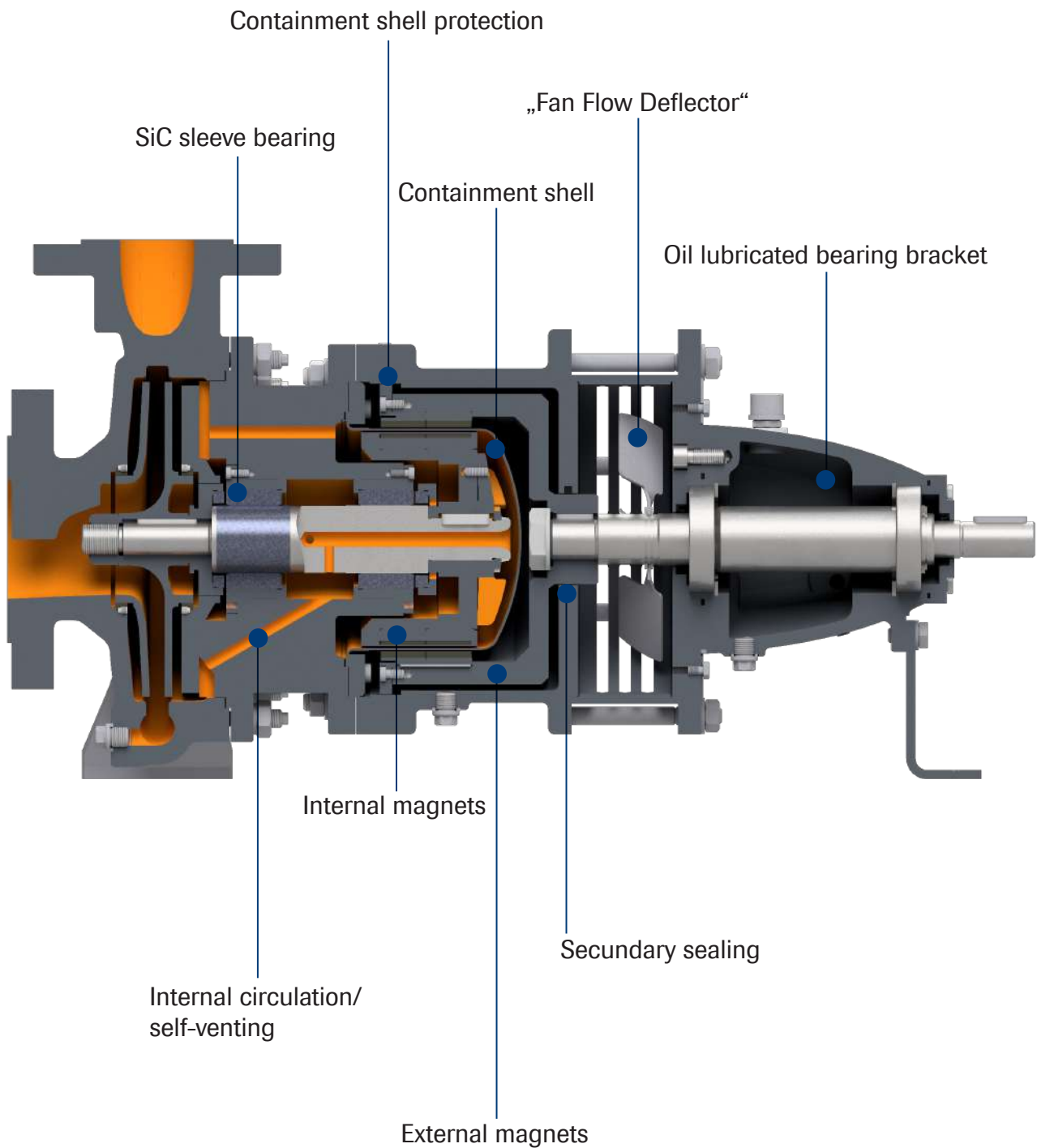

Address

Dickow Pumpen
GmbH & Co. KG
Siemensstrasse 22
D-84478 Waldkraiburg

Phone

+49 (0)8638 602-0

Internet

info@dickow.de
www.dickow.de

Homepage:

