

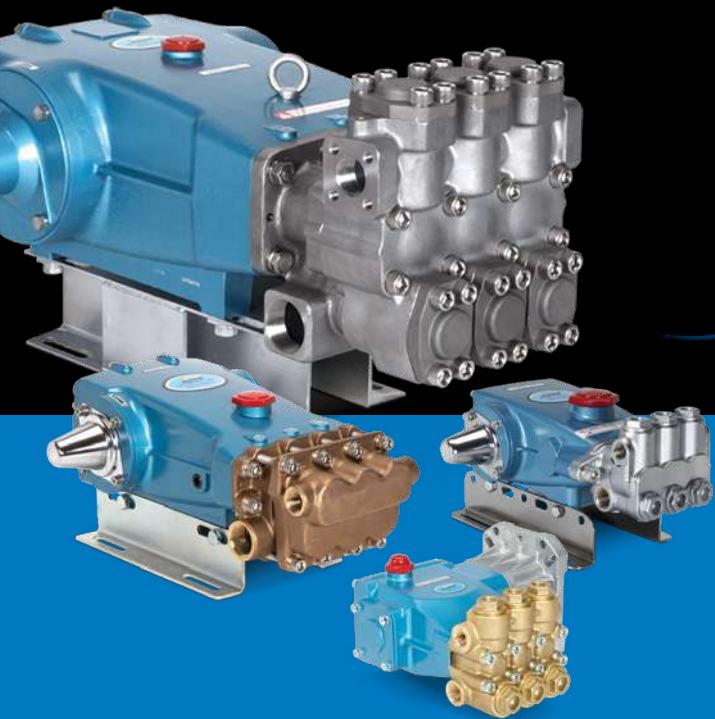

Pump Catalog

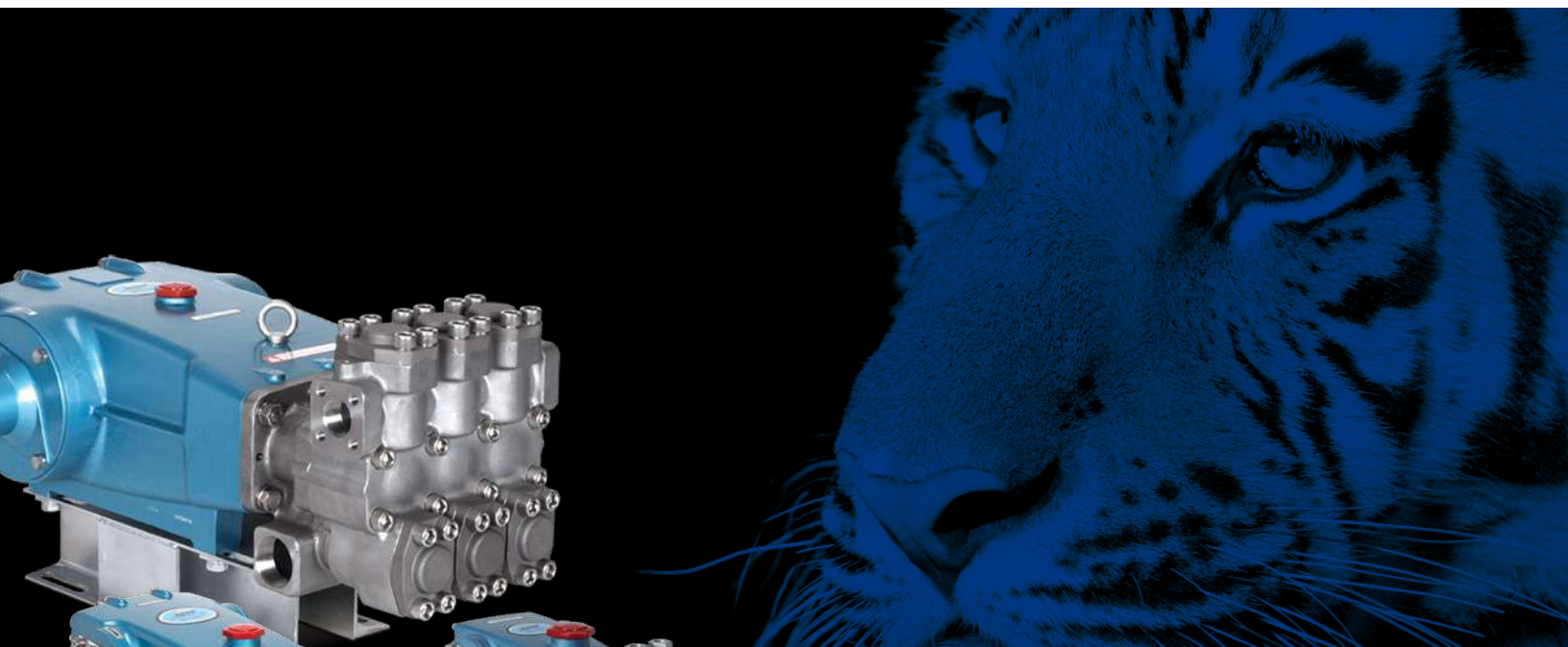

Product Quality, Reliability and Support You Expect

www.catpumps.com

World Leader in Triplex Reciprocating High-Pressure Pumps

Cat Pumps designs and builds products to the highest quality level for one major reason: our customers depend on our products to keep their equipment running. Every design detail is optimized for long product life and reliable performance.

Cat Pumps embraces a zero defect manufacturing philosophy. Stringent process controls result in highly repeatable processes, yielding the highest level of product reliability. Cat Pumps commitment to quality is legendary within the industry, earning the trust from customers worldwide. When it needs to run, make it Cat Pumps.

Product Performance Range

A wide range of pump options are available, including a variety of products that meet various industry certifications and directives.

- Flow: 0.13 to 240 gpm (0.49 to 908 lpm)
- Pressure: 100 to 10,000 psi (6.9 to 689 bar)
- RPM: 100 to 3450
- Liquid Temperature: -10° to 240°F (-23° to 115°C)
- Manifold Materials: Brass, Nickel Aluminum Bronze, 304 and 316 Stainless Steel, Duplex Stainless Steel
- Drives: Electric, Engine, Hydraulic, Pneumatic



Product Ordering

Using This Catalog

The pump sections of this catalog are organized by drive type/flow rate/manifold materials: brass, 316 stainless steel, duplex stainless steel and nickel aluminum bronze. The model numbers listed represent standard pumps equipped with Buna-N seals and O-rings, except for specialty pumps, such as CO₂, TEG and portable extractor, which are fitted with unique seals for the application.

Standard Buna-N pump seals and/or O-rings can be changed by adding a suffix to the standard model number that represents the desired new seal material.

Optional Seal and O-Ring Configurations		
MATERIAL CODE	DESCRIPTION	PUMP MODEL SUFFIX
FPM	Fluorocarbon (Viton®) seals and O-rings, chemical resistance, rated to 180° F (82° C)	.0110
EPDM	Ethylene Propylene Diene Monomer seals and O-rings	.0220
HT	High-temperature seal for plunger pump high pressure seals High-temperature V-HOT cup for piston pumps, rated to 190° F (87° C)	.3000
STHT	Special Teflon® high temperature low and high pressure seals, rated to 200° F (93° C)	.3400
PTFE	Pure Polytetrafluoroethylene (Teflon®) seals and Buna-N O-rings Pure Polytetrafluoroethylene (Teflon®) seals and FPM O-rings	.0700 .0710
IPFE	Pure Polytetrafluoroethylene (Teflon®) seals and Isolast O-rings	.0770
NBRS	Buna-N silicone free seals and O-rings	.6000
ST4	Special blend Polytetrafluoroethylene high and low pressure seals, FPM O-Rings, FPM crankcase elastomer	.44101

Viton® and Teflon® are registered trademarks of DuPont Dow Elastomers.

Example

Pump model 3535 can be changed from Buna-N to either FPM or EPDM. To convert pump model 3535 from Buna-N seals and O-rings to FPM (Viton®), add the suffix (.0110) to the standard pump model number (3535.0110). Use this new number when ordering the pump.

Cat Pumps configures a number of pumps for special applications and certifications such as ATEX, CO₂, TEG, Flushed, High-Temp and others. Please contact Cat Pumps directly at (763) 780-5440 for more information.

Table of Contents

Direct Drive Plunger Pumps	Page 6	Piston Pumps	Page 14
Hollow Shaft: Brass Manifold	6 – 7	Specialty Pumps	15
Hollow Shaft: 316 Stainless Steel	7	Flushed Manifold Pumps	15
Gearbox: Brass Manifold	7	High Temperature Pumps	16
Gearbox: 316 Stainless Steel Manifold	8	Triethylene Glycol (TEG) Pumps, 240° F	16
Bell Housing: Brass Manifold	8	Washout Resistant Pumps	17
Bell Housing: 316 Stainless Steel Manifold	8	Liquid CO ₂ Pumps	17
Bell Housing: 316 Nickel Aluminum Bronze Manifold	9	ATEX Pumps	18
Belt Drive Plunger Pumps		1CX Series Compact Misting Pumps	18
Brass and 304 Stainless Steel	10 – 11	1XP Series Portable Extractor Pumps	19
316 Stainless Steel	12	Centrifugal Pumps	20
Duplex Stainless Steel	13	Accessories	21
Nickel Aluminum Bronze	13	Custom Pumping Systems	22 – 23

Selecting your pump

Plunger Pumps (0.13 – 240 gpm, 100 – 10,000 psi)

Plunger pumps utilize spring-loaded closed and hydraulically opened inlet and discharge valves to direct flow through the pump manifold. At the beginning of the stroke, the plunger displaces the liquid in the manifold chamber, forcing the discharge valve open. When the plunger reaches the end of the stroke, the discharge valve closes. As the plunger rod begins its backward stroke, the inlet valve opens to allow more liquid into the manifold chamber, thereby keeping a smooth forward flow of liquid.

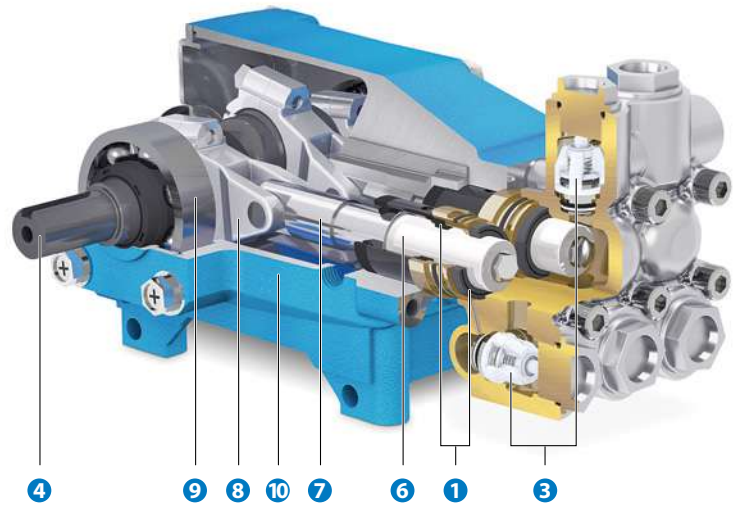

XP Series Pumps (0.5 – 2 gpm, 100 – 1,000 psi)

In XP series pumps, fluid enters the inlet port and flows through the drive-end, lubricating the connecting rods and plunger rods as it passes to the inlet valves. Both inlet and discharge valves are spring-loaded closed and hydraulically opened, similar to plunger pumps, however, they utilize a flow-through ceramic plunger design. The continuous forward flow characteristics in conjunction with the packing design of plunger pumps result in improved suction capabilities as well as extended seal life.

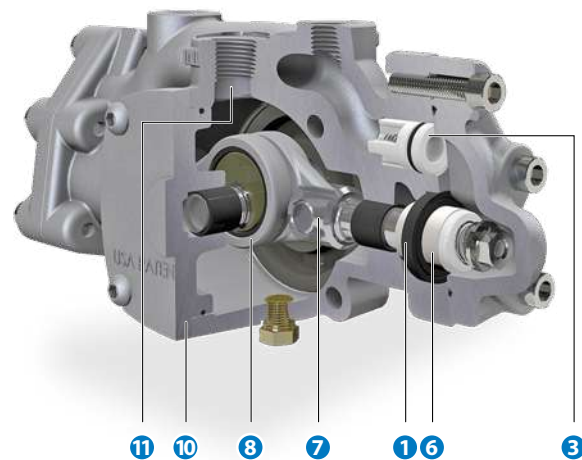

Features

- 1 Specially formulated, Cat Pumps exclusive high pressure and low pressure seals offer unmatched performance and seal life.
- 2 100% wet cup/seal design adds to service life by allowing pumped fluids to cool and lubricate the elastomers on both sides.
- 3 Stainless steel valves, seats, and springs provide corrosion-resistance, positive seating, and long life.
- 4 Chrome-moly crankshaft provides unmatched strength and surface hardness for long life.
- 5 The patented stepped piston rod with hard chrome-plated sleeve provides a durable wear surface and easy wet end servicing.
- 6 Precision-polished, solid ceramic plungers provide maximum resistance to corrosion and abrasion, extending seal life.

Piston Pumps (3.0 – 60 gpm, 100 – 1,500 psi)

The design of the piston pump is for the fluid to move continually in one, smooth forward direction. This design allows greater suction capabilities and reduces the risk of cavitation provided the pump is properly primed. At the beginning of the stroke, the mechanically actuated inlet valve (and piston) will close. As the piston rod moves forward, the liquid is forced out through the discharge valves. Simultaneously, the liquid enters the pump inlet and flows in behind the inlet valve. As the piston rod begins the backward stroke, the inlet valve mechanically opens, permitting the liquid to continue its flow forward through the piston into the discharge chamber.

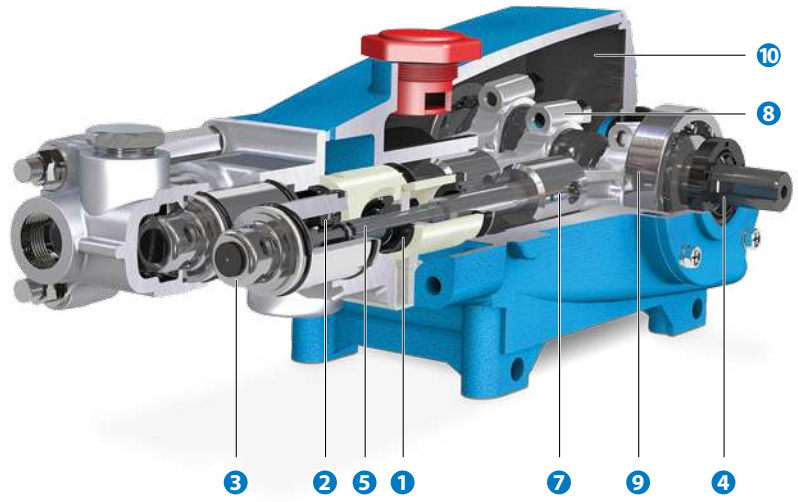

SF Series Pumps (0.5 – 5 gpm, 100 – 3,500 psi)

In SF series pumps, both the inlet and discharge valves are spring-loaded closed and hydraulically opened, similar to plunger pumps, however, they have a flow-through ceramic plunger design. The continuous forward flow characteristic of piston pumps is utilized in conjunction with the packing design of the plunger pumps. These features give SF pumps both strong suction capabilities and higher pressure performances.

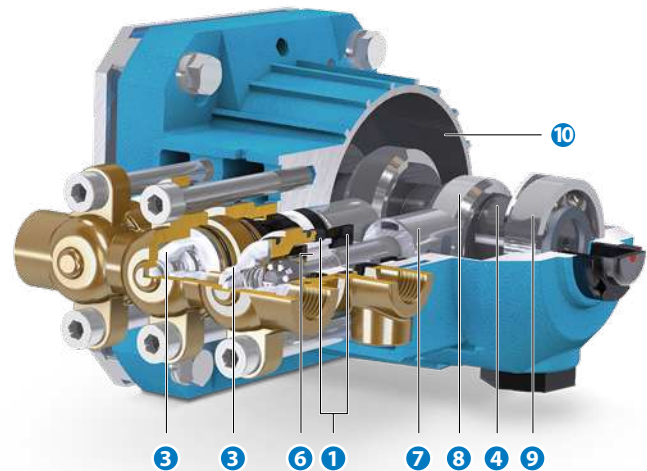

- 7 The high strength stainless steel plunger rods have a 360° supported crosshead providing uncompromising plunger rod alignment.
- 8 Matched oversized connecting rods are made of high strength material with exceptional bearing quality.
- 9 Oversized ball bearings or tapered roller bearings provide extended bearing life.

- 10 High Strength, light weight die cast aluminum crankcase with splash oil design allows operation at speeds as low as 100 RPM.
- 11 Patented greaseless design uses water from inlet as lubrication, eliminating the maintenance and mess of grease or oil.